

iMAT Turnstile interface board

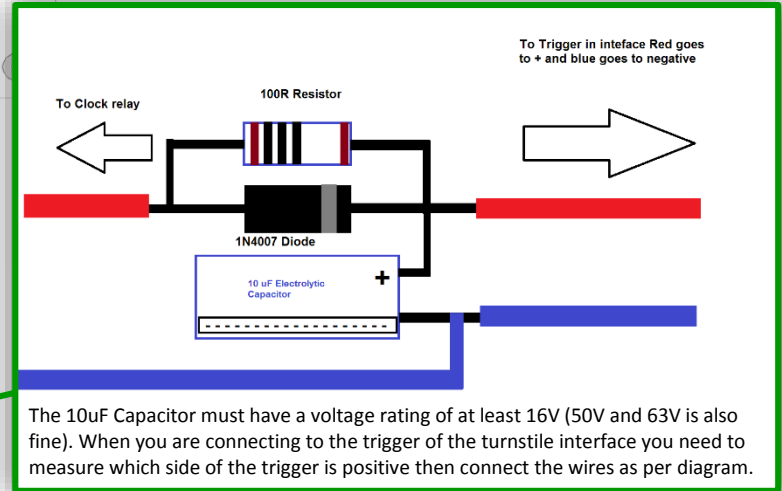

Electronic cluster enables "slow trigger" mode, effectively increasing the minimum relay contact duration for the iMAT Turnstile interface board.

The 10uF Capacitor must have a voltage rating of at least 16V (50V and 63V is also fine). When you are connecting to the trigger of the turnstile interface you need to measure which side of the trigger is positive then connect the wires as per diagram.

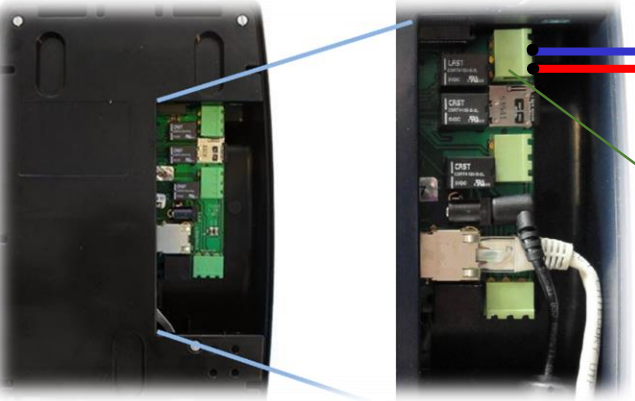
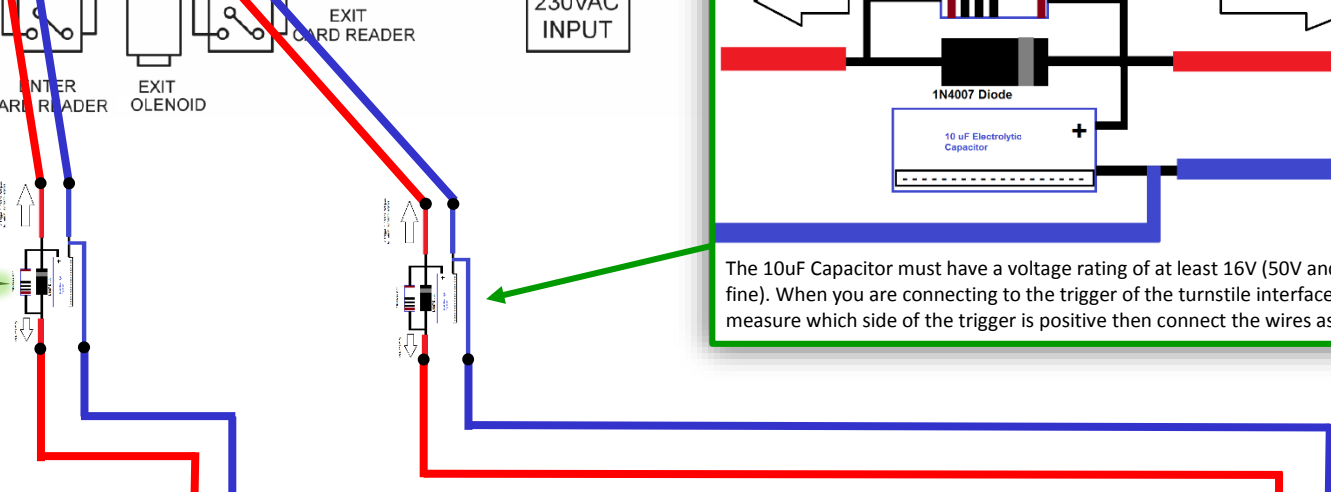

Connector for Relay 1

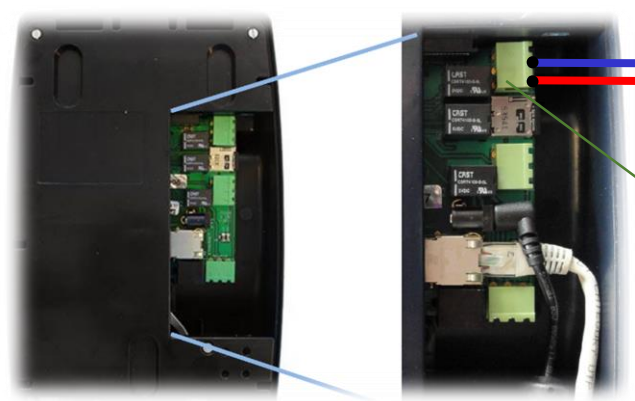

Connector for Relay 1

3370 CS Timeclock 1 (Set to IN only)

3370 CS Timeclock 2 (Set to OUT only)